

# SPECIFICATION

Product Name: Integrated Air Quality Sensor Module

Model: AM1008W-K

Version: V1.1

Date: May 5, 2020

| Writer | Audit | Approved |
|--------|-------|----------|
| Kwon   |       |          |

# Revision

| No. | Version | Content   | Reviser | Date       |
|-----|---------|---|---------|------------|
| 1   | V1.0    | Revision  | Kwon    | 2019-07-17 |
| 2   | V1.1    | Correction of temperature and humidity measurement range and accuracy. (See specifications)<br>Corrected the measurement range of temperature and humidity. (Refer to protocol specification) | Kwon    | 2020-05-05 |

# Integrated Air Quality Sensor Module

AM1008W-K



## Applications

- Air purifier
- Air quality monitor
- Air conditioner
- Ventilation system
- Consumer electronic products
- Environmental monitoring

## Description

AM1008W is an indoor air quality sensor module with highly integrated ultra-thin laser particle sensor, NDIR CO<sub>2</sub> sensor, semiconductor VOC sensor, temperature, and humidity sensor, which can real-time output digital measurement data. It is with stable performance, compact structure design, multi-function and optional connection ways, which can be widely used for IAQ monitor, air purifier, ventilation system, air conditioner, etc.

## Features

- Highly integrated with sensors including laser particle, NDIR CO<sub>2</sub>, VOC, temperature, humidity for option
- The NDIR CO<sub>2</sub> sensor is with high low power consumption, auto-calibration
- Ultra-thin (height is only 12mm) laser particle sensor with four working mode
- Easy to install and debugging simply
- With voltage regulator design and EMC compliant, strong anti-static ability

## Working Principle

- The PM sensor integrated adopts laser scattering technology to simultaneously detect PM1.0, PM2.5, PM10 mass concentration
- The CO<sub>2</sub> sensor integrated adopts NDIR technology to detect indoor CO<sub>2</sub> concentration
- The VOC sensor is based on semiconductor principle
- The RH&T sensor integrated adopts capacitance resistance materials to detect indoor RH&T

## Specifications

### Integrated Indoor Air Quality Sensor Specification

|   |  |
|---|--|
| Operating principle                       | CO <sub>2</sub> : NDIR technology<br>PM: laser scattering technology<br>VOC: semiconductor   |
| Measurement range                         | PM: 0 ~ 1,000ug/m <sup>3</sup><br>CO <sub>2</sub> : 0 ~ 5,000ppm<br>VOC: 0 ~ 3 level<br>Temperature: -40°C ~ 85°C<br>RH: 5 ~ 95%RH   |
| Maximum consistency error for PM1.0/PM2.5 | ≤100ug/m <sup>3</sup> , ±10ug/m <sup>3</sup><br>>100ug/m <sup>3</sup> , ±10% of reading<br>Condition: 25 ±2°C, 50±10%RH,<br>Reference instrument: GRIMM 11-A<br>Dust Source: Cigarette + Arizona A1        |
| Maximum consistency error for PM10        | 0 ~ 100ug/m <sup>3</sup> , ±25ug/m <sup>3</sup><br>101 ~ 1,000ug/m <sup>3</sup> , ±25% reading<br>Condition: 25 ±2°C, 50±10%RH,<br>Reference instrument: GRIMM 11-A<br>Dust Source: Cigarette + Arizona A1 |
| CO <sub>2</sub> measurement accuracy      | ± (50ppm+5% of reading) @25 ±2°C, 50 ±10%RH  |
| Temperature accuracy                      | ±0.4 °C (max), -40 to 85 °C  |
| Humidity accuracy                         | ± 4% RH (max), 5 ~ 80% RH,<br>± 6.5% RH (max), 80 ~ 99% RH   |
| PM preheating time                        | ≤8 sec   |
| CO <sub>2</sub> preheating time           | ≤30 sec  |
| VOC preheating time                       | ≤120 sec   |
| Data refresh rate                         | 1 sec  |
| Working condition                         | -10 ~ 50°C, 0 ~ 99%RH (Non-condensing)   |
| Storage condition                         | -20 ~ 60°C, 0 ~ 99%RH (Non-condensing)   |
| Working voltage                           | DC 5V ±0.1V, ripple wave < 50mV  |
| Average working current                   | ≤300mA   |
| Signal output                             | UART TTL (3.3V TTL), I2C   |
| Dimension                                 | W80mm × H50mm × D13.6mm  |
| Life span                                 | MTTF of PM sensor= 37,297Hrs (continuous turn on)<br>CO <sub>2</sub> ≥10 years<br>VOC ≥10 years  |

## Dimensions and Connector

### 1. Dimensions (Unit mm, tolerance $\pm 0.2$ mm)

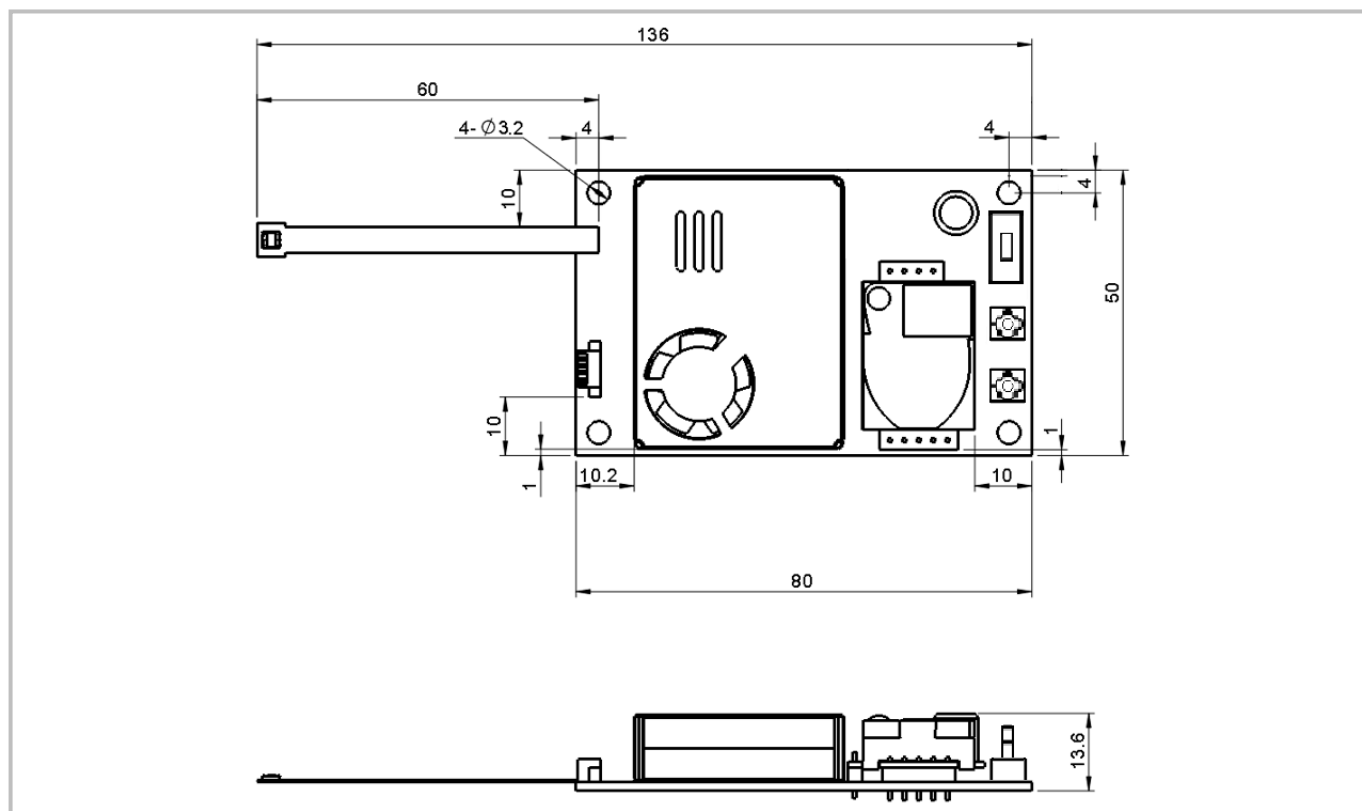

### 2. I/O Connector Pin out

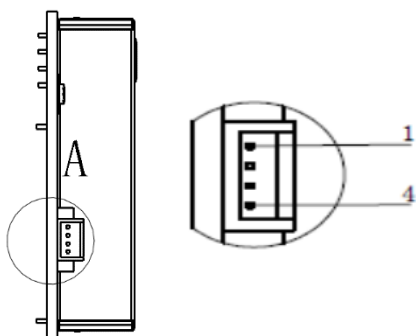

| No. | Pin    | Description                            |
|-----|--------|--|
| 1   | GND    | Power supply input (GND)               |
| 2   | RX/SDA | UART-RX input (TTL@3.3V) / I2C data    |
| 3   | TX/SCL | UART-TX output (TTL @3.3V) / I2C Clock |
| 4   | +5V    | Power supply input (+5V)               |

### 3. Connector and Cables

| Item      | Part Number | Pitch  | Recommendation Manufacturer |
|-----------|-------------|--------|-----------------------------|
| Connector | 12505WR-04  | 1.25mm | YEONHO ELECTRONICS          |
| Cables    | 12505HS-04  | 1.25mm | YEONHO ELECTRONICS          |

## Application Circuit

### Application 1: UART TTL 3.3V UART output

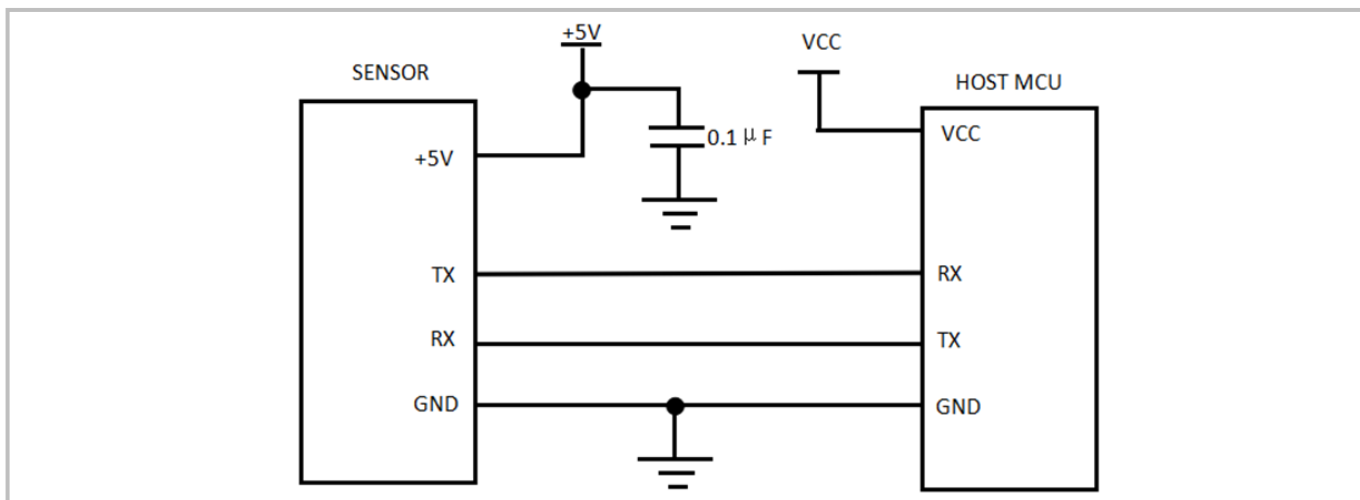

### Application 2: I2C 3.3V output

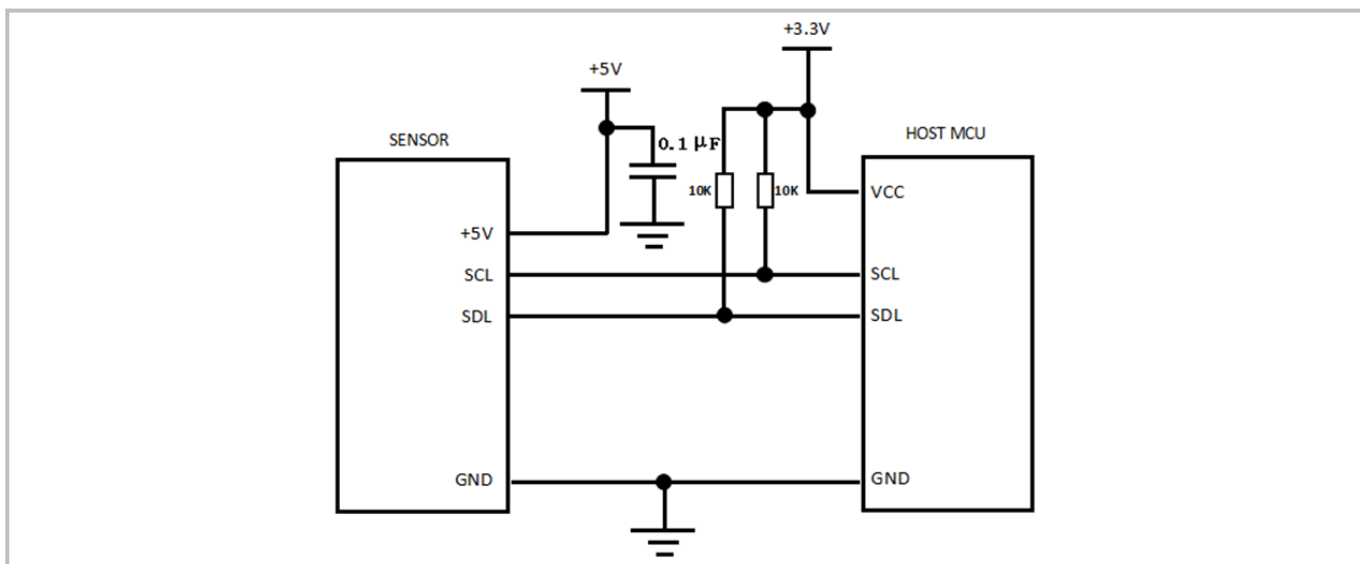

### Test scenarios 3: 3.3V ~ 5V switching circuit diagram

If host MCU is 5V, it need:

take 5V transfer to 3V.

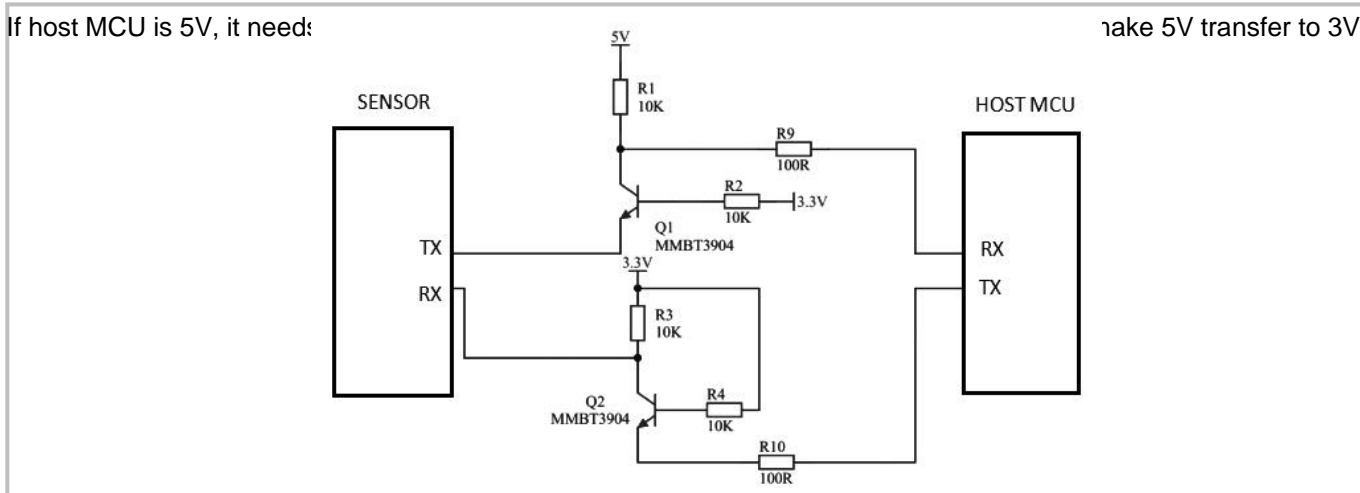

## Temperature Influence Curve

### PM Temperature Influence Curve

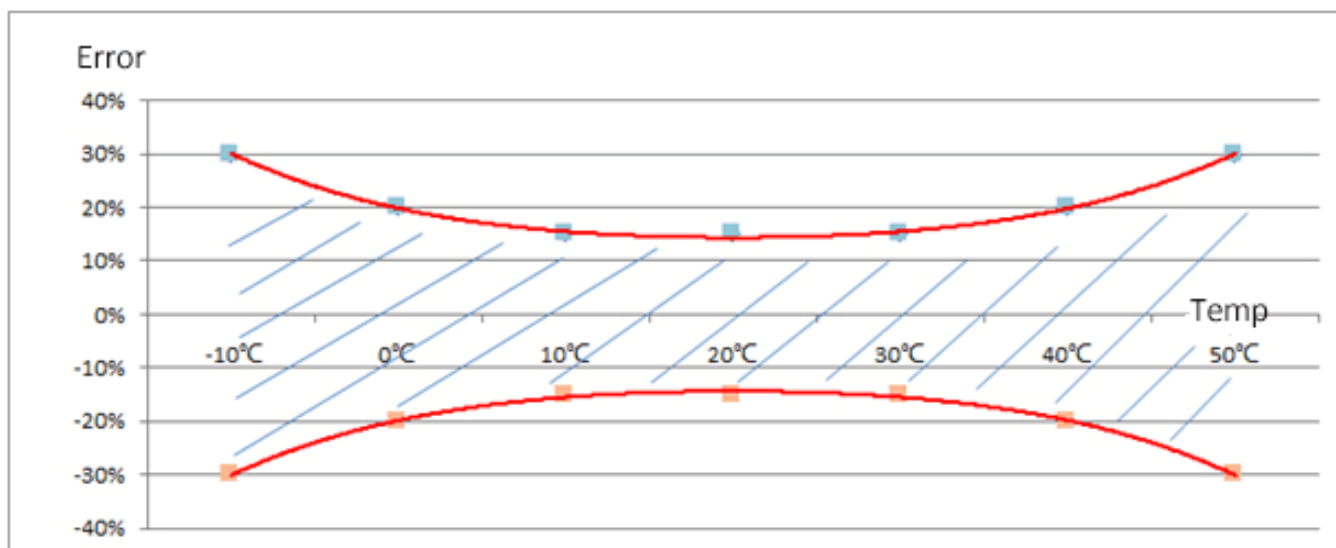

Measured error: under  $25^{\circ}\text{C} \pm 2^{\circ}\text{C}$ ,  $50 \pm 10\% \text{RH}$ ,  $0 \sim 1,000 \mu\text{g}/\text{m}^3$ , consistency and accuracy of  $\text{PM}_{1.0}/\text{PM}_{2.5}$  is  $\pm 10\%$  reading or  $\pm 10 \mu\text{g}/\text{m}^3$ , take the biggest value

Temperature influence coefficient:  $0.5\%/\text{C} \sim 1\%/\text{C}$  or  $0.5 \mu\text{g}/\text{m}^3/\text{C} \sim 1 \mu\text{g}/\text{m}^3/\text{C}$ , take the biggest value.

## Product Installation

- When installing AM1008W module in your system or equipment, please make sure of unobstructed air-inlet and air- outlet. And there is no huge airflow faced to air-inlet and air-outlet.
- In order to avoid dust deposition on the surface of the sensitive component (laser diode and photosensitive diode), which may affect the measurement accuracy of the sensor, the appropriate installation ways are recommended as below.

**Recommended Installation**

**Non-Recommended Installation**

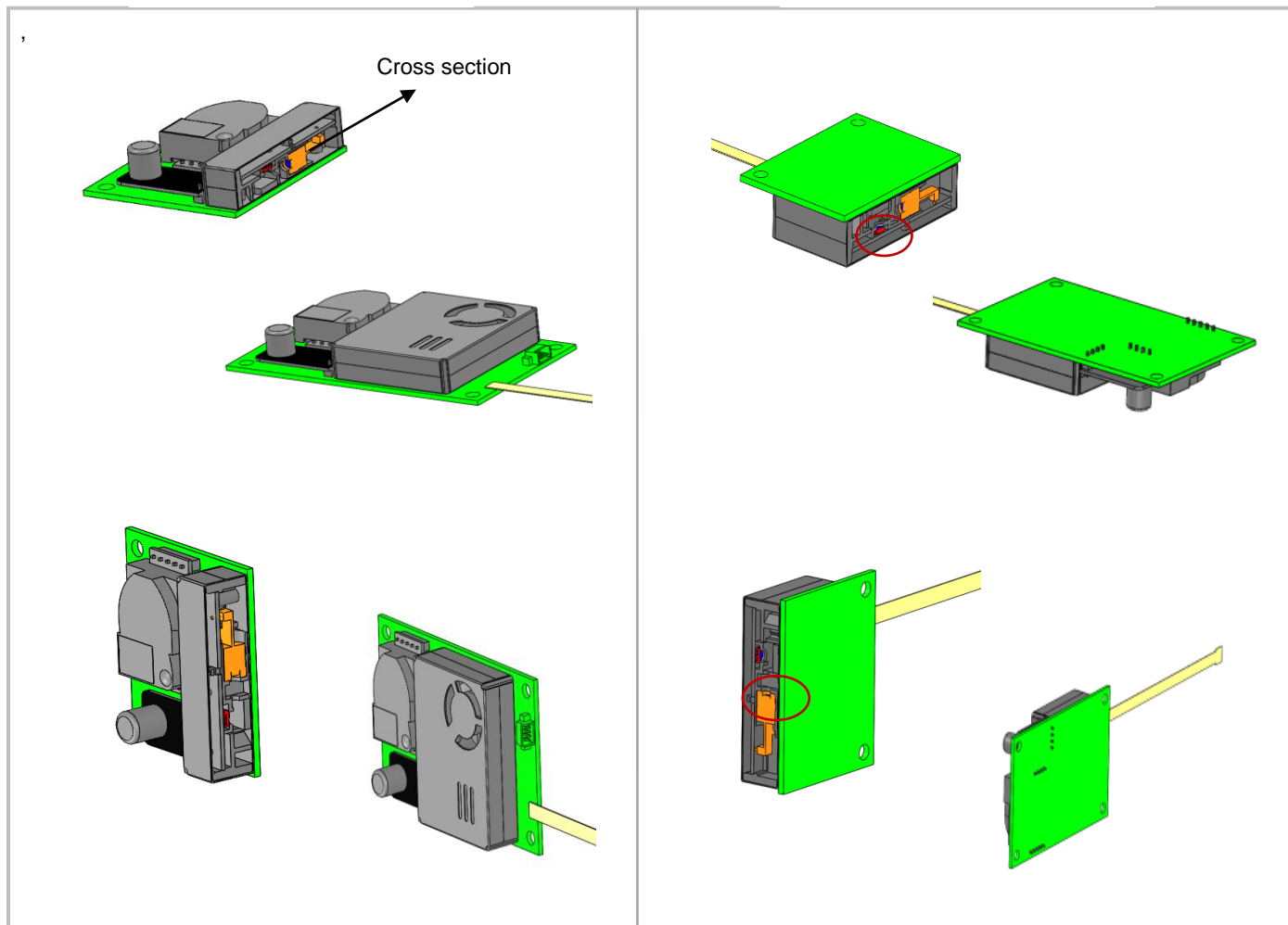

The blue is the front of  
laser diode

The blue is the front of  
photodiode

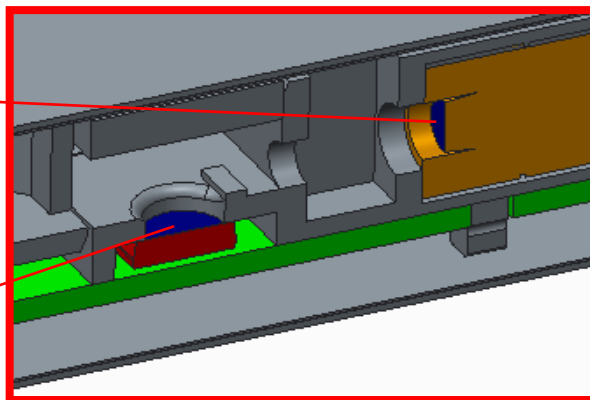



## User Attention

---

- AM1008W sensor module is for household electronics products. For application of medical, mining, disaster preparedness, which needs high security and high dependence, this sensor is not suitable.
- The laser dust sensor adopts non-static adsorption materials such as metal, please avoid to working under the high particle concentration environment.
- When you use the laser dust sensor, please make sure of unobstructed air-inlet and air-outlet. The CO<sub>2</sub>, VOC using diffusion for sampling, the gas diffusion hole should be reserved.
- This sensor module should avoid working outdoors or in the heavy dust environment. Protection against sandstorm, rain, snow and willow floccus should be completed by the user equipment.
- When using the laser dust sensor, it's recommended to add 50 ~ 60 mesh protective filters to the air inlet position, to prevent the pollution of large particles of dust, floccules, hair etc on the detection data.
- When the sensor module is applied to air purifier or detection equipment, the sensor should be installed more than 20cm above the ground, to avoid the fan couldn't work normally due to the pollution of large dust and floccus.

## Caution

**If "UART Command" is transmitted within 10 seconds after the power is supplied to the AM1008W-K, the sensor module is fixed to "UART Communication Mode".**

**When using AM1008W-K in I2C communication mode, 10 seconds must elapse after power is supplied.**

## UART Communication Protocol

### 1. General Statement

- 1). The data in this protocol are all hexadecimal data. Such as "46 for decimal [70]"
- 2). [xx] for single-byte data (unsigned, 0 ~ 255); high byte of double byte data is in the front, the low byte in the back
- 3). Baud rate: 9,600, data bits: 8, stopbits:1, parity: No.

### 2. Format of Serial Communication Protocol

Sending format of software:

| Start Symbol | Length | Command | Data 1 | ..... | Data n. | Check Sum |
|--------------|--------|---------|--------|-------|---------|-----------|
| HEAD         | LEN    | CMD     | DATA1  | ..... | DATAn   | CS        |
| 11H          | XXH    | XXH     | XXH    | ..... | XXH     | XXH       |

Detail description on protocol format:

| Protocol Format | Description   |
|-----------------|---|
| Start           | Command sending fixed [11H], the module respond fixed [16H] |
| Length          | Frame bytes length= data length +1 (including CMD+DATA)     |
| Command         | Command   |
| Data            | Data of writing or reading, unfixed length                  |
| Check sum       | Cumulative sum of data= 256 - (HEAD+LEN+CMD+DATA)           |

### 3. Command Table of Serial Protocol

| Item No. | Function Description                            | Command   |
|----------|---|-----------|
| 1        | Read measurement result                         | 0x01 0x01 |
| 2        | CO <sub>2</sub> calibration                     | 0x03      |
| 3        | Open / close particle measurement               | 0x0C      |
| 4        | Set up and read particle measurement time       | 0x0D      |
| 5        | Set up and read timing measurement mode         | 0x05      |
| 6        | Set up and read dynamic working mode            | 0x06      |
| 7        | Set up and read particle calibrated coefficient | 0x07      |
| 8        | Open / close laser diode                        | 0x08      |
| 9        | Read software version                           | 0x1E      |
| 10       | Read serial number                              | 0x1F      |

## 4. Protocol Description

### 4.1 Read Measurement Result

**Send:** 11 02 01 01 EB (DF0 added)

**Response:** 16 16 01 DF1 DF2 DF3 DF4 DF5 DF6 DF7 DF8 DF9 DF10 DF11 DF12 DF13 DF14 DF15 DF16 DF17 DF18 DF19 DF20 DF21 [CS]

**Function:** to read CO<sub>2</sub>, VOC, RH, Temp, PM1.0, PM2.5, PM10, VOC Now / Ref. %, VOC Ref. R Value, VOC Now R Value [CS]

Statement:

Response data bit:

16 16 01 02 C2 00 03 00 32 00 19 00 53 00 63 00 73    00 64            00 FA            00 FA            00    40  
                  CO<sub>2</sub>   VOC   RH   Temp   PM<sub>1.0</sub>   PM<sub>2.5</sub>   PM<sub>10</sub>   VOC Now/Ref. %   VOC Ref. R Value   VOC Now R Value   state   CS

| Item             | Data Bit      | Decimal Effective Value Range | Corresponding Value        | Multiple |
|------------------|---------------|-------------------------------|----------------------------|----------|
| CO <sub>2</sub>  | [DF1] [DF2]   | 0 ~ 5,000                     | 0 ~ 5,000 ppm              | 1        |
| VOC              | [DF3] [DF4]   | 0 ~ 3                         | 0 ~ 3 level                | 1        |
| Related humidity | [DF5] [DF6]   | 50 ~ 990                      | 5.0 ~ 99.0 %               | 10       |
| Temperature      | [DF7] [DF8]   | 100 ~ 1,350                   | -40 ~ 85°C                 | 10       |
| PM1.0 (GRIMM)    | [DF9] [DF10]  | 0 ~ 1,000                     | 0 ~ 1,000ug/m <sup>3</sup> | 1        |
| PM2.5 (GRIMM)    | [DF11] [DF12] | 0 ~ 1,000                     | 0 ~ 1,000ug/m <sup>3</sup> | 1        |
| PM10 (GRIMM)     | [DF13] [DF14] | 0 ~ 1,000                     | 0 ~ 1,000ug/m <sup>3</sup> | 1        |
| VOC Now / Ref. % | [DF15] [DF16] | 0 ~ 1,000                     | 0 ~ 1,000%                 | 1        |
| VOC Ref. R Value | [DF17] [DF18] | 0 ~ 65,000                    | 0 ~ 650,000Ω               | 0.1      |
| VOC Now R Value  | [DF19] [DF20] | 0 ~ 65,000                    | 0 ~ 650,000Ω               | 0.1      |
| State            | [DF21]        |                               |                            | 1        |

1. Temperature data is added 500 upon practical measurement result.

For example, -20°C is corresponding to value 300. Temperature value= (DF7 \* 256 + DF8 - 500) / 10.

2. The measurement result comes out with two data bits, high bit is on the head, and the low bit is after then.

Measurement result= DF<sub>n</sub> \* 256 + DF<sub>n+1</sub>

3. Status bit: status alarming. (When the working temperature and fan speed of PM2008 is abnormal)

| Byte     | Bit7     | Bit6     | Bit5     | Bit4     | Bit3                          | Bit2                           | Bit1                          | Bit0                           |
|----------|----------|----------|----------|----------|-------------------------------|--------------------------------|-------------------------------|--------------------------------|
| Alarming | Reserved | Reserved | Reserved | Reserved | 1: Working temperature is low | 1: Working temperature is high | 1: Fan at low revolving speed | 1: Fan at high revolving speed |

### 4.2 CO<sub>2</sub> Calibration

**Send:** 11 03 03 DF1 DF2 [CS]

**Response:** 16 01 03 E6

**Function:** CO<sub>2</sub> calibration

**Statement:** Format statement:

| Item                     | Data Bit    | Decimal Effective Value Range | Corresponding Value | Multiple |
|--------------------------|-------------|-------------------------------|---------------------|----------|
| Calibration target value | [DF1] [DF2] | 400 ~ 1,500                   | 400 ~ 1,500 ppm     | 1        |

1. Calibration target value= DF1 \* 256 + DF2
2. Before CO<sub>2</sub> calibration, make sure that the current ambient CO<sub>2</sub> value is the target value you want to calibrate and that the stable time is at least 2 minutes.

#### 4.3 Open and Close Particle Measurement

**Send:** 11 03 0C DF1 1E [CS]

**Response:** 16 02 0C DF1 [CS]

**Function:** open and close particle measurement

**Statement:**

1. When send command, DF1= 02 is measurement open; DF1= 01 is measurement close;
2. When respond command, DF1= 02 is measurement open; DF1= 01 is measurement close;
3. When the sensor receives command for measurement open, it will go into continuous measuring mode;

If send: 11 03 0C 02 1E C0 // open particle measurement

Response: 16 02 0C 02 DA // the sensor module is under measurement open status

If send: 11 03 0C 01 1E C1 // close particle measurement

Response: 16 02 0C 01 DB // the sensor module is under measurement close status

#### 4.4 Set up and Read Particle Measuring Time

**Send:** 11 03 0D DF1 DF2 [CS] // set up particle measuring time

**Send:** 11 01 0D E1 // read particle measuring time

**Response:** 16 03 0D DF1 DF2 [CS]

**Function:** Read particle measuring time

**Note:**

1. Particle measuring time= DF1 \* 256 + DF2, unit is second. Minimum measuring time is 36 seconds. Time range is 36 ~ 65,535 seconds. After setting up xx seconds particle measuring time, the sensor will stop working first, then you can send "Open / command" to start single xx seconds measuring.
2. When measuring time is  $\geq 65,531$ , it means module will be in continuous measuring mode once powered on. It will not stop until "stop" command is sent.

#### Continuously working mode:

When continuously measuring mode is set, sensor situation is 2. When PM1.0 is less than 5ug/m<sup>3</sup>, then measuring is close (situation changes to 0x80, only the laser diode turns off for 5 seconds) and outputs the last value in standby mode. After 5 seconds, the PM sensor resumes the measurement for 4 seconds, If PM1.0 measuring data within the 4sec is less than 5ug/m<sup>3</sup>, then measuring is close (situation changes to 0x80, only the laser diode turns off for 5 seconds). Otherwise, the sensor will go ahead testing until the PM1.0 measuring data is less than 5ug/m<sup>3</sup>.

**Example:**

**Send:** 11 03 0D 00 24 BB // set up single measuring mode; measuring time is 36sec

**Response:** 16 03 0D 00 24 B6 // measuring time is set up successfully

**Send:** 11 03 0D FF FF E1 // set up continuously measuring mode (Repowering on means to start measuring status)

**Response:** 16 03 0D FF FF DC // continuously measuring mode is set up successfully

**Send:** 11 01 0D E1 // read particle measuring time

**Response:** 16 03 0D FF FF DC // read successfully

**4.5 Set up Timing Measuring Mode**

**Send:** 11 03 05 DF1 DF2 [CS] // set up particle measuring mode

**Send:** 11 01 05 E9 // read particle measuring mode

**Response:** 16 03 05 DF1 DF2 [CS]

**Function:** Read particle measuring time

**Note:**

1. Particle measuring mode value  $X = DF1 * 256 + DF2$ , unit is second;
2. When  $X \geq 180$ , it means module is under timing measuring mode. Measurement timing cycle is X seconds. The sensor module will start measurement every X second. Default measuring time is 36 seconds.
3. Range for X, minimum timing period is 3 minutes

**Send:** 11 03 05 02 05 E0 // Set up as timing measuring mode, and timing cycle is 517 seconds.

**Response:** 16 03 05 02 05 DB // Set up successfully

**4.6 Set up Dynamic Measuring Mode**

**Send:** 11 02 06 DF1 [CS] // Set up dynamic particle measuring mode

**Send:** 11 01 06 E8 // Read dynamic particle measuring mode

**Response:** 16 02 06 DF1 [CS]

**Function:** Read / set up particle dynamic measuring mode

**Note:**

1. Particle dynamic measuring mode result DF1.
2. When DF1= 0, close dynamic measuring mode. When DF1= 1, start dynamic measuring mode.

**Dynamic Working Mode:**

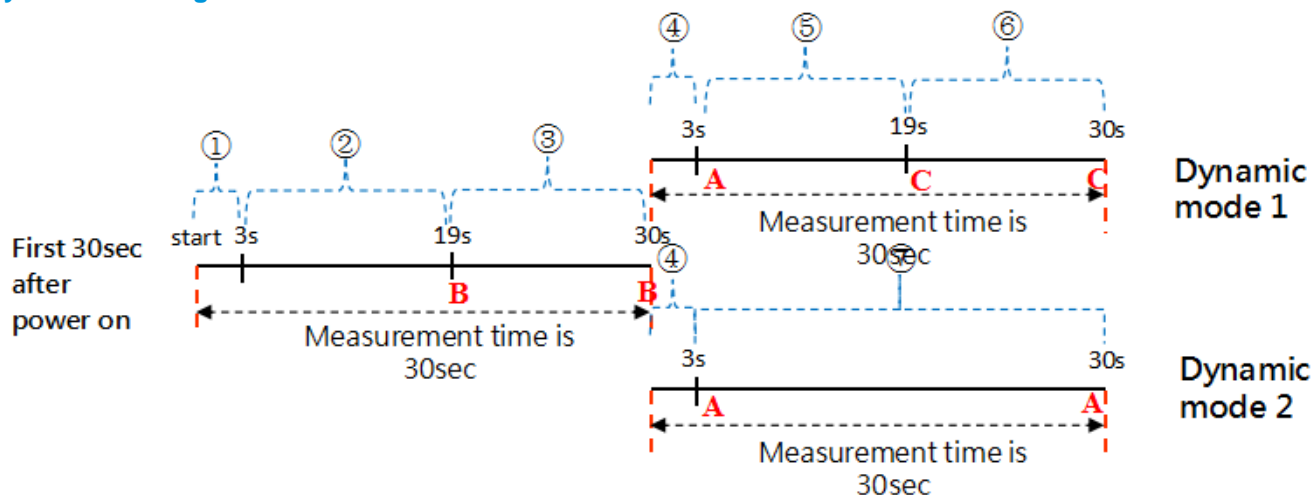

After sensors are in dynamic working mode, start measuring every 30sec. The sensor starts the measurement for the first 3 seconds.

After 3 seconds of measurement, the sensor starts measuring again continuously for 16 seconds and outputs the B value.

The laser diode turns off for 11 seconds, enters the standby state, and outputs the B value.

After the first 30 second period, the sensor starts a new 3 second measurement and outputs the A value.

① If  $|A-B| > 10\mu\text{g}/\text{m}^3$  or  $|A-B| / B > 10\%$ , the sensor selects Dynamic mode 1. The sensor measures continuously for 16 seconds and outputs the C value.

The laser diode turns off for 11 seconds, enters the standby state, and outputs the C value.

② If  $|A-B| < 10\mu\text{g}/\text{m}^3$  or  $|A-B| / B < 10\%$ , the sensor selects Dynamic mode 2 and stores A value, then enters standby state for 27 seconds and outputs A value.

Regardless of the dynamic mode A or B, the sensor starts a new 30 second measurement cycle by starting the initial 3 second measurement. Compare the measured value with the previously stored value for the initial 3 seconds and select Dynamic mode 1 or 2 again.

**Send:** 11 02 06 01 E6 // Set up opening dynamic particle measuring mode

**Response:** 16 02 06 01 E1 // Set up successfully

**Send:** 11 02 06 00 E7 // Set up closing dynamic particle measuring mode

**Response:** 16 02 06 00 E2 // Set up successfully

**The module can support 4 kinds of working mode (Single + Continuous + Timing + Dynamic).**

It can be switched between these 4 kinds of working mode.

It is continuous working mode by default after leaving factory.

These 4 kinds of working mode can be switched by sending commands, as following:

1. Send: 11 03 0D 00 24 BB // Single measuring mode, time is 36sec
2. Send: 11 03 0D FF FF E1 // Continuously measuring mode
3. Send: 11 03 05 02 05 E0 // Timing measuring mode, interval time is 517 seconds
4. Send: 11 02 06 01 E6 // Dynamic measuring mode

#### 4.7 Set up and Read Particle Calibrated Coefficient

**Send:** 11 02 07 DF1 [CS] // Set up particle calibrated coefficient. DF1 means calibrated coefficient

**Send:** 11 01 07 E7 // Read particle calibrated coefficient

**Response:** 16 02 07 DF1 [CS]

**Function:** Read / set up particle calibrated coefficient

#### Note:

1. Range 70 ~ 150. Corresponding coefficient: 0.7 ~ 1.5. [DF1: 64(HEX) → 100(DEC) → 1.0]

#### Description:

1. When there is difference between standard device, calibrated coefficient can be set to correct the final value.
2. When calibrated coefficient is set, the value of PM1.0, PM2.5, and PM10 will be all corrected by this coefficient.

#### 4.8 Close / Open Laser Diode

**Send:** 11 02 08 04 E1 // Close laser diode

**Send:** 11 01 08 E6 // Read status

**Response:** 16 02 08 04 DC

**Note:**

When laser diode is closed, the sensor will stop measuring but the FAN will stay working. The measuring data will keep the same with the last time measured data. If to open the laser diode again, you can use "Open/ close particle measurement" command.

#### 4.9 Read Software Version Number

**Send:** 11 01 1E D0

**Response:** 16 0B 1E DF1 DF2 DF3 DF4 DF5 DF6 DF7 DF8 DF9 DF10 [CS]

**Function:** Read software version

**Note:**

Software version= "DF1 ~ DF10"

Should change the HEX code to ASCII code.

**Example:**

HEX code: 16 0E 1E 50 4D 20 56 31 2E 32 36 2E 35 2E 32 38 E9

ASCII code: PM V1.26.5.28

#### 4.10 Read Serial Number

**Send:** 11 01 1F CF

**Response:** 16 0B DF1 ~ DF10 [CS]

**Function:** Read serial number

**Note:** Serial number= DF1 ~ DF10

**Example:**

**Response:** 16 0B 1F 00 00 00 7E 09 07 07 0E 0D 72 9E

**Serial number:** 126 2311 1806 3442

#### 4.11 VOC sensor baseline adjustment

**Send:** 11 03 09 00 00 E3

**Response:** 16 03 09 00 00 CS

**Function:** To do baseline adjustment of VOC sensor

**Note:** 00 00 is the reserved byte

## I2C Communication Protocol

### 1. Brief Introduction

This is an I2C protocol for AM1008W. The sensor module is lower computer, which is not able to initiate communication automatically. Communication is initiated via main controlled board, which reads data and sends control commands.

I2C Communication clock frequency  $\leq 30\text{KHz}$ .

### 2. Communication Common Description

START: start signal, send by main controlled board;

STOP: stop signal, send by main controlled board;

ACK: acknowledge signal, send by the sensor module if in bold; otherwise, send by main controlled board;

NACK: non-acknowledge signal, send by the sensor module if in bold; otherwise, send by main controlled board;

Dx: receive and send data; send by the sensor module if in bold; otherwise, send by main controlled board.

### 3. Protocol Detailed Description

#### 3.1 Send Command Data

Receive by main controlled board:

START+WRITE+ACK+D1+ACK+ D2+ACK..... +D7+ACK+STOP

| Data           | Byte Content   | Description   |
|----------------|--|---|
| Device address | Sensor address and read / write command  | This byte is 0x <b>50</b> when write data   |
| D1             | 0x16   | Frame header  |
| D2             | Frame length   | Number of bytes, not including the length of device address (From D1 to D7, 7 bytes in total)   |
| D3             | Data1  | Control command of the PM Sensor:<br>Close measurement: 0x01; Open measurement: 0x02<br>Set up single measurement: 0x0D<br>Set up continuously measurement: 0x0C<br>Set up timing measurement: 0x05; Set up dynamic measurement: 0x06<br>Other function: CO <sub>2</sub> calibration: 0x03; Set up PM calibration coefficient: 0x07 |
| D4             | Time data, high byte<br>DF1/CO <sub>2</sub><br>Calibration value, high byte / PM Coefficient | Time data: Set the working mode time of PM2.5 sensor<br>Total time= DF1 * 256 + DF2, Unit(s)<br>Details as below:<br>CO <sub>2</sub> Calibration value= DF1 * 256 + DF2, Unit: ppm;<br>PM Coefficient: Set the coefficient of Dust sensor   |
| D5             | Time data, low byte DF2/CO <sub>2</sub><br>Calibration value, low byte                       |   |
| D6             | Reserve  |   |
| D7             | Data check code  | Check code= (D1^D2^.....^D6)  |



## Description and Setting Working Mode for PM Sensor

1. PM Sensor power on default continuously working mode
2. PM Sensor have 4 working mode: continuously measure, dynamic measuring, single measurement, timing measurement. It must be in one of working mode when the sensor power on.
3. PM Sensor can be switched in all the working modes, when power off, it will not save the working mode. If power on again, it defaults continuously working mode

### 4. Dynamic Measuring Mode:

After sensors are in dynamic measuring mode, the measuring cycle is 30 seconds.

The sensor starts the measurement for the first 3 seconds. If measuring result within 3 seconds compared with the last time measured result meets situation ① the sensor will go on testing for another 16 sec, then the measurement is closed for 11 sec (only laser diode is off) until next new 30 sec measuring cycle.

Change range is  $>\pm 10\mu\text{g}/\text{m}^3$  or  $>\pm 10\%$

If measuring result within 3 seconds compared with the last time measured result meets situation ②, the measurement is closed for 27 sec until the next new 30 sec measurement cycle starts.

② Change range is  $<\pm 10\mu\text{g}/\text{m}^3$  or  $<\pm 10\%$

5. Timing mode and single mode need to combine with P4, P5 to set the time. Details as below table:

| PM Sensor Mode           | D4    | D5  | Description  | Remark   |
|--------------------------|-------|-----|--|--|
| Close                    | ----- |     | Byte data is no meaning to measurement   |  |
| Open                     | ----- |     | Byte data is no meaning to measurement   | After closed then open the measurement mode like before                  |
| Single measurement       | DF1   | DF2 | Single measurement range:<br>36 ~ 65,530 Unit: sec<br>It's invalid if not in this range  |  |
| Continuously measurement | ----- |     | Byte data is no meaning to measurement   |  |
| Timing measurement       | DF1   | DF2 | Timing measurement range:<br>180 ~ 65,530 Unit: sec<br>It's invalid if not in this range | Start the measurement for each cycle, and the measurement time is 36 sec |
| Dynamic measurement      | ----- |     | Byte data is no meaning to measurement   |  |

### Other description:

1. Set the PM coefficient, calibration coefficient range: 70 ~ 150, Corresponding calibration coefficient: 0.7 ~ 1.5.
2. Set the calibration value of CO<sub>2</sub>, the range is 400 ~ 1,500 ppm.
3. CO<sub>2</sub> measurement range is 0 ~ 5,000ppm.

## Read Data Command

Send by main controlled board: START+READ+ACK+D1+ACK+D2+ACK+.....+D25+NACK+STOP

| Data           | Byte Content                            | Description  |
|----------------|---|--|
| Device address | Sensor address and read / write command | This byte is 0x51 when read data   |
| D1             | 0x16                                    | Frame header   |
| D2             | Frame length                            | Number of bytes, not including the length of device address. (From D1 ~ D25, 25 bytes in total)  |
| D3             | PM2.5 Sensor status                     | Close: 0x00; Single measuring mode: 0x0D<br>Continuous measuring mode: 0x0C<br>Timing measuring mode: 0x05; Dynamic measuring mode: 0x06 |
| D4             | Data 1 High byte                        | CO <sub>2</sub> concentration, Unit: PPM   |
| D5             | Data 1 Low byte                         |  |
| D6             | Data 2 High byte                        | VOC level output   |
| D7             | Data 2 Low byte                         |  |
| D8             | Data 3 High byte                        | Humidity, Unit: %RH [Humidity= (measure data / 10)]  |
| D9             | Data 3 Low byte                         |  |
| D10            | Data 4 High byte                        | Temperature, Unit: °C [Temperature= (measure data - 500) / 10]   |
| D11            | Data 4 Low byte                         |  |
| D12            | Data 5 High byte                        | PM1.0  |
| D13            | Data 5 Low byte                         |  |
| D14            | Data 6 High byte                        | PM2.5  |
| D15            | Data 6 Low byte                         |  |
| D16            | Data 7 High byte                        | PM10   |
| D17            | Data 7 Low byte                         |  |
| D18            | Data 8 High byte                        | VOC Now R / Ref. R (%)   |
| D19            | Data 8 Low byte                         |  |
| D20            | Data 9 High byte                        | VOC Ref. R Value   |
| D21            | Data 9 Low byte                         |  |
| D22            | Data 10 High byte                       | VOC Now R Value  |
| D23            | Data 10 Low byte                        |  |
| D24            | State                                   | State  |
| D25            | Data check code                         | check code= (D1^D2^ ~ ^D24)  |

### Status alarm (Status of PM2008)

| Byte     | Bit7     | Bit6     | Bit5     | Bit4     | Bit3                          | Bit2                           | Bit1                          | Bit0                           |
|----------|----------|----------|----------|----------|-------------------------------|--------------------------------|-------------------------------|--------------------------------|
| Alarming | Reserved | Reserved | Reserved | Reserved | 1: Working temperature is low | 1: Working temperature is high | 1: Fan at low revolving speed | 1: Fan at high revolving speed |

## Packing Information

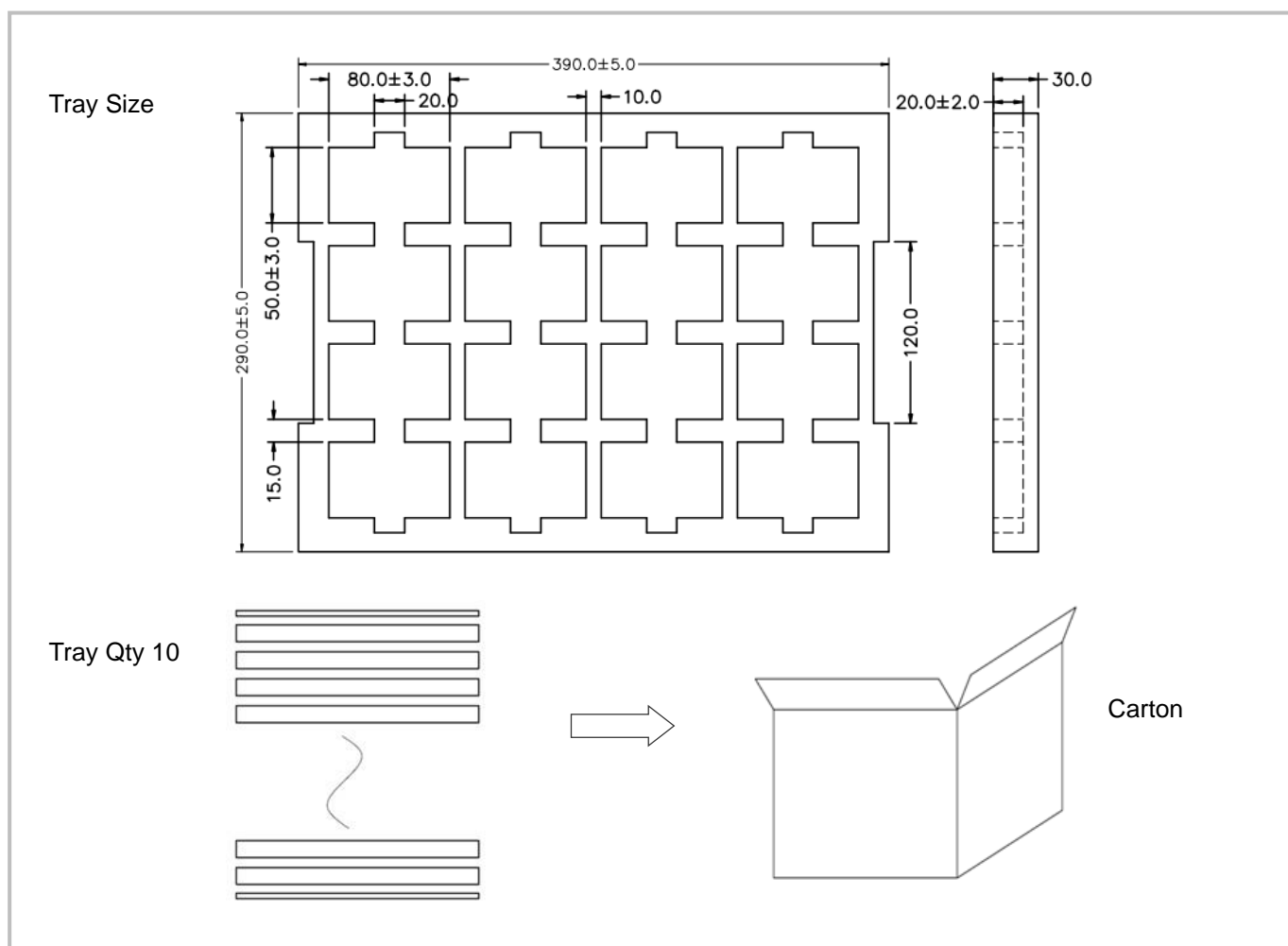

| Sensor per Tray | Tray Qty  | Sensor per Carton | Carton Dimensions | Packing Material    |
|-----------------|-----------|-------------------|-------------------|---------------------|
| 16 pcs          | 10 layers | 160pcs            | 395 * 310 * 330mm | Red anti-static EPE |

## After-Sales Services and Consultancy

**Cubic Sensor and Instrument Co., Ltd**

Tel: +86 (0)27 81628827 / Fax: +86 (0)27 81628821 / South Korea Contact +82 **010-5349-8385**

Add: Fenghuang No.3 Road, Fenghuang Industrial Park, Eastlake Hi-tech Development Zone, Wuhan 430205, China

Web: [www.gassensor.com.cn](http://www.gassensor.com.cn) / E-mail: [info@gassensor.com.cn](mailto:info@gassensor.com.cn) / South Korea Contact [malbonair@naver.com](mailto:malbonair@naver.com)